

PA

PA1100

Saw attachment
Accessoire de sciage
Suplemento de sierra



GB Operator's manual
FR Manuel d'utilisation
ES Manual de instrucciones

KEY TO SYMBOLS

Symbols

WARNING! The machine can be a dangerous tool if used incorrectly or carelessly, which can cause serious or fatal injury to the operator or others.



Please read the operator's manual carefully and make sure you understand the instructions before using the machine.



Always wear:

- A protective helmet where there is a risk of falling objects
- Approved hearing protection
- Protective goggles or a visor



This product is in accordance with applicable EC directives.



Saw attachment with shaft PA 1100

This machine is not electrically insulated. If the machine touches or comes close to high-voltage power lines it could lead to death or serious bodily injury. Electricity can jump from one point to another by arcing. The higher the voltage, the greater the distance electricity can jump. Electricity can also travel through branches and other objects, especially if they are wet. Always keep a distance of at least 10 m between the machine and high-voltage power lines and/or any objects that are touching them. If have to work within this safe distance you should always contact the relevant power company to make sure the power is switched off before you start work.

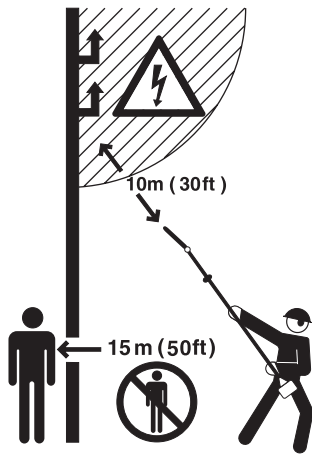

Saw attachment without shaft PA

This machine is not electrically insulated. If the machine touches or comes close to high-voltage power lines it could lead to death or serious bodily injury. Electricity can jump from one point to another by arcing. The higher the voltage, the greater the distance electricity can jump. Electricity can also travel through branches and other objects, especially if they are wet. Always keep a distance of at least 10 m between the machine and high-voltage power lines and/or any objects that are touching them. If have to work within this safe distance you should always contact the relevant power company to make sure the power is switched off before you start work.

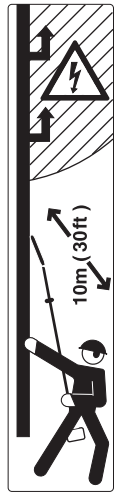

Always wear approved protective gloves.



Wear sturdy, non-slip boots.



Other symbols/decals on the machine refer to special certification requirements for certain markets.

Switch off the engine by moving the stop switch to the STOP position before carrying out any checks or maintenance.

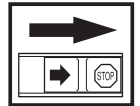

Always wear approved protective gloves.



Regular cleaning is required.

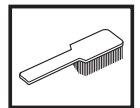

Visual check.



Protective goggles or a visor must be worn.



Filling with chain oil and adjusting oil flow



CONTENTS

Contents

KEY TO SYMBOLS

Symbols 2

CONTENTS

Contents 3

Note the following before starting: 3

SAFETY INSTRUCTIONS

Cutting equipment 4

Specification of bar and saw chain 4

Sharpening your chain and adjusting raker clearance . 5

Tensioning the chain 6

Lubricating cutting equipment 7

Checking wear on cutting equipment 8

Safety instructions for using a pruning saw 8

WHAT IS WHAT?

What is what on the saw attachment? (Saw attachment with shaft PA 1100) 11

What is what on the saw attachment? (Saw attachment without shaft PA) 12

ASSEMBLY

Fitting the cutting head (Saw attachment with shaft PA 1100)..... 13

Fitting the cutting head (Saw attachment without shaft PA) 13

Fitting the bar and chain 13

Fitting the hanging ring 13

Adjusting the harness 14

Filling with oil 14

Check before starting 14

TECHNICAL DATA

Technical data 15

Bar and chain combinations 15

EC-declaration of conformity 16

Note the following before starting:

Jonsered has a policy of continuous product development and therefore reserves the right to modify the design and appearance of products without prior notice.

Long-term exposure to noise can result in permanent hearing impairment. So always use approved hearing protection.

Please read the operator's manual carefully and make sure you understand the instructions before using the machine.

These instructions supplement the instructions that were included with the machine. For other procedures, please refer to the operating instructions for the machine.



WARNING! Under no circumstances may the design of the machine be modified without the permission of the manufacturer. Always use genuine accessories. Non-authorized modifications and/or accessories can result in serious personal injury or the death of the operator or others.



WARNING! This accessory may only be used together with the intended clearing saw/trimmer, see under heading "Approved accessories" in chapter Technical data in the machine's Operator's Manual.

The machine is only designed for cutting branches and twigs.

SAFETY INSTRUCTIONS

Cutting equipment

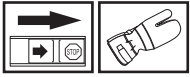

This section describes how you can achieve maximum clearing capacity and extend the life of the cutting attachment through correct maintenance and using the right type of cutting attachment.

Only use cutting equipment recommended by us! See the Technical data section.

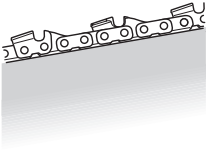

Keep the chain's cutting teeth properly sharpened! Follow our instructions and use the recommended file gauge. A damaged or badly sharpened chain increases the risk of accidents.

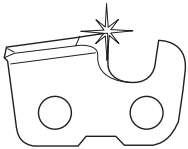

Maintain the correct raker clearance! Follow our instructions and use the recommended raker gauge. Too large a clearance increases the risk of kickback.

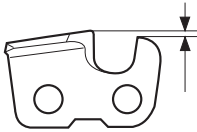

Keep the chain properly tensioned! If the chain is slack it is more likely to jump off and lead to increased wear on the bar, chain and drive sprocket.

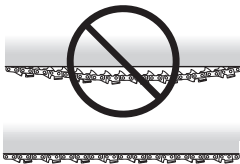

Keep cutting equipment well lubricated and properly maintained! A poorly lubricated chain is more likely to break and lead to increased wear on the bar, chain and drive sprocket.

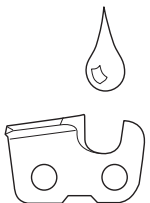

WARNING! Never use a machine with faulty safety equipment. The machine's safety equipment must be checked and maintained as described in this section. If your machine fails any of these checks contact your service agent to get it repaired.



WARNING! Always stop the engine before doing any work on the cutting attachment. This continues to rotate even after the throttle has been released. Ensure that the cutting attachment has stopped completely and disconnect the HT lead from the spark plug before you start to work on it.

Specification of bar and saw chain

When the cutting attachment supplied with your machine has to be replaced, because it is worn out or damaged, you must only fit the types of bar and saw chain recommended by us.

Bar

- Length (inches/cm)

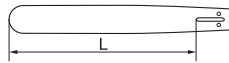

- Number of teeth on bar tip sprocket (T). Small number = small tip radius = low risk of kickback.

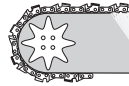

- Chain pitch (inches). The spacing between the drive links of the chain must match the spacing of the teeth on the bar tip sprocket and drive sprocket.

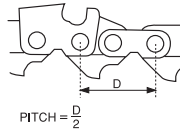

- Number of drive links. The number of drive links is determined by the length of the bar, the chain pitch and the number of teeth on the bar tip sprocket.



- Bar groove width (inches/mm). The groove in the bar must match the width of the chain drive links.



- Saw chain oil hole and hole for chain tensioner pin.

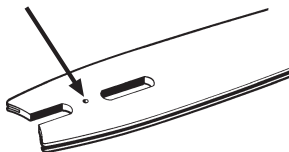

SAFETY INSTRUCTIONS

Chain

- Saw chain pitch (inches). (The distance between three drive links, divided by two.)

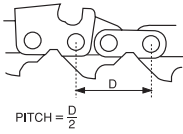

- Drive link width (mm/inches)

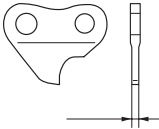

- Number of drive links.



Sharpening your chain and adjusting raker clearance



WARNING! The risk of kickback is increased with a badly sharpened chain!

General information on sharpening cutting teeth

- Never use a blunt chain. When the chain is blunt you have to exert more pressure to force the bar through the wood and the cuttings will be very small. If the chain is very blunt it will not produce any cuttings at all. Wood powder would be the only result.
- A sharp chain eats its way through the wood and produces long, thick cuttings.

The cutting part of the chain is called the cutting link and this consists of a cutting tooth (A) and the raker lip (B). The cutting depth is determined by the difference in height between the two.

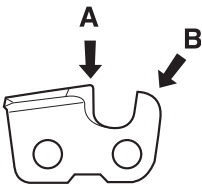

- When you sharpen a cutting tooth there are five important factors to remember.

1 Filing angle

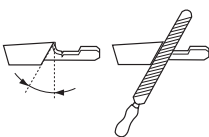

2 Cutting angle

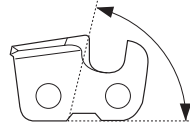

3 File position

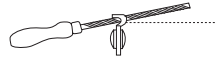

4 Round file diameter

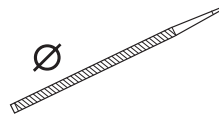

5 File depth

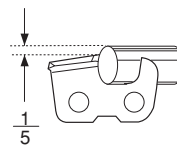

It is very difficult to sharpen a chain correctly without the right equipment. We recommend that you use our file gauge. This will help you obtain the maximum kickback reduction and cutting performance from your chain.

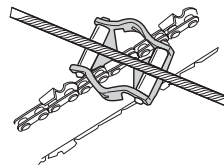

WARNING! The following faults will increase the risk of kickback considerably:

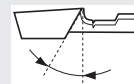

File angle too large

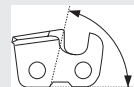

Cutting angle too small



File diameter too small

Sharpening cutting teeth



- To sharpen cutting teeth you will need a round file and a file gauge.

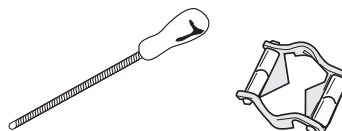

SAFETY INSTRUCTIONS

- Check that the chain is correctly tensioned. A slack chain will move sideways, making it more difficult to sharpen correctly.



- Always file cutting teeth from the inside face outwards. Reduce the pressure on the return stroke. File all the teeth on one side of the bar first. Then turn the saw over and file the remaining teeth from the other side.

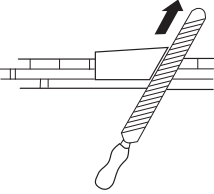

- File all the teeth to the same length. When the length of the cutting teeth is reduced to 4 mm (0.16") the chain is worn out and should be replaced.

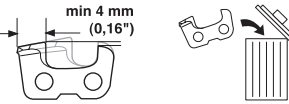

General advice on setting raker clearance

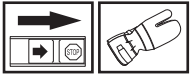

- When you sharpen the cutting teeth you reduce the raker clearance (=cutting depth). To maintain optimal cutting performance you must file back the raker lip to the recommended height.

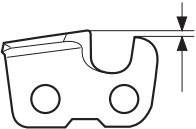

- On a low-kickback cutting link the front edge of the raker lip is rounded. It is very important that you maintain this radius or bevel when you adjust the raker clearance.



- We recommend that you use our raker gauge to achieve the correct clearance and bevel on the raker lip.

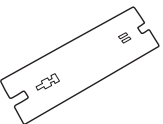

WARNING! The risk of kickback is increased if the raker clearance is too large!

Setting the raker clearance

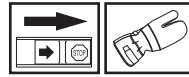

- Before setting the raker clearance the cutting teeth should be newly sharpened. We recommend that you adjust the raker clearance every third time you sharpen the chain. **NOTE!** This recommendation assumes that the length of the cutting teeth is not reduced excessively.
- To adjust the raker clearance you will need a flat file and a raker gauge.

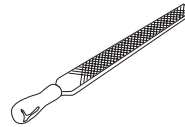

- Place the gauge over the raker lip.

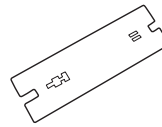

- Place the file over the part of the lip that protrudes through the gauge and file off the excess. The clearance is correct when you no longer feel any resistance as you draw the file over the gauge.

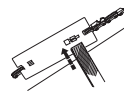

Tensioning the chain

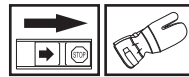

WARNING! A slack chain may jump off and cause serious or even fatal injury.

- The more you use a chain the longer it becomes. It is therefore important to adjust the chain regularly to take up the slack.
- Check the chain tension every time you refuel. **NOTE!** A new chain has a running-in period during which you should check the tension more frequently.

SAFETY INSTRUCTIONS

- Tension the chain as tightly as possible, but not so tight that you cannot pull it round freely by hand.

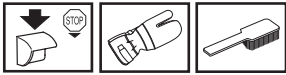
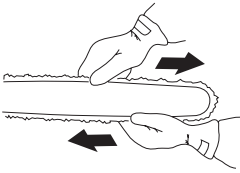

- 1 Undo the bar nut.

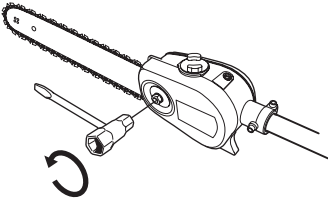

- 2 Raise the tip of the bar and stretch the chain by tightening the chain tensioning screw using the combination spanner. Tighten the chain until it does not sag from the underside of the bar.

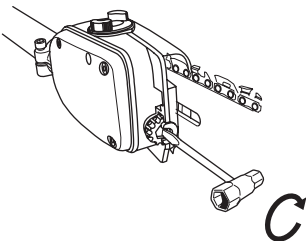

- 3 Use the combination spanner to tighten the blade nut while holding up the tip of the bar. Check that you can pull the saw chain round freely by hand.

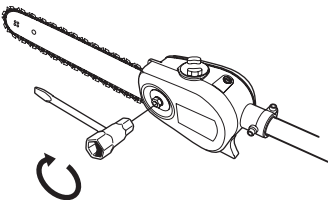

Lubricating cutting equipment



WARNING! Poor lubrication of cutting equipment may cause the chain to snap, which could lead to serious, even fatal injuries.

Chain oil

- Chain oil must demonstrate good adhesion to the chain and also maintain its flow characteristics regardless of whether it is warm summer or cold winter weather.
- As a chain saw manufacturer we have developed an optimal chain oil which, with its vegetable oil base, is also biodegradable. We recommend the use of our own oil for both maximum chain life and to minimise environmental damage.
- If our own chain oil is not available, standard chain oil is recommended.

- In areas where oil specifically for lubrication of saw chains is unavailable, ordinary EP 90 transmission oil may be used.
- **Never use waste oil!** This is dangerous for yourself, the machine and the environment.

Filling with chain oil



The oil pump is preset at the factory to meet most lubrication requirements. A full oil tank will last about half as long as a full tank of fuel. You should therefore check the level of oil in the oil tank regularly to avoid damage to the saw chain and bar that could occur due to lack of lubrication.

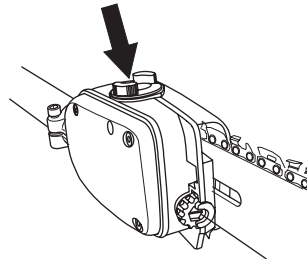

Checking chain lubrication

Check the chain lubrication each time you refuel.

Aim the tip of the bar at a light coloured surface about 20 cm (8 inches) away. After 1 minute running at 3/4 throttle you should see a distinct line of oil on the light surface.

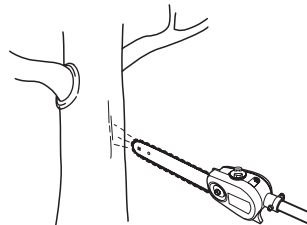

Adjusting chain lubrication

When cutting dry or hard species of wood it may be necessary to increase lubrication. Turn the adjuster screw anticlockwise to increase the oil flow. Remember that this will increase oil consumption, check the level in the oil tank regularly. Turn the adjuster screw clockwise to decrease the oil flow.

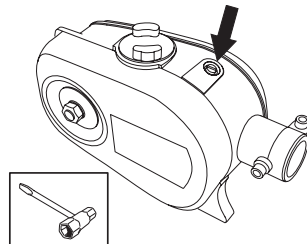

SAFETY INSTRUCTIONS

What to do if lubrication does not work:

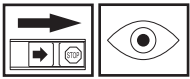

- 1 Check that the oil channel in the bar is not obstructed. Clean if necessary.

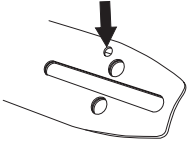

- 2 Check that the oil channel in the gear housing is clean. Clean if necessary.
- 3 Check that the bar tip sprocket turns freely. If the chain lubrication system is still not working after carrying out the above checks you should contact your service workshop.

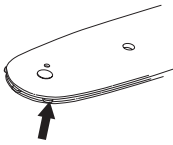

Checking wear on cutting equipment

Chain

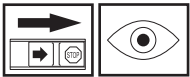

Check the chain daily for:

- Visible cracks in rivets and links.

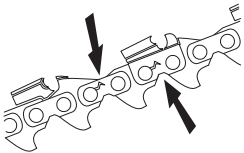

- Whether the chain is stiff.
- Whether rivets and links are badly worn.

We recommend you compare the existing chain with a new chain to decide how badly the existing chain is worn.

When the length of the cutting teeth has worn down to only 4 mm the chain must be replaced.

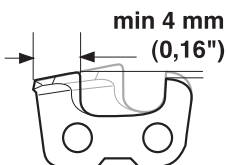

Chain drive sprocket



Regularly check the degree of wear on the drive sprocket. Replace if wear is excessive.

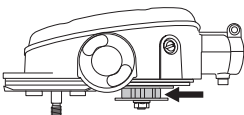

Vibration damping system

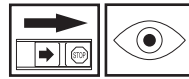

Check regularly that the vibration damping element is free from cracks. Check regularly the degree of wear to the rubber dampers. Replace them if worn.

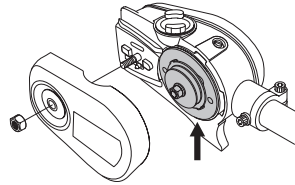

Bar



Check regularly:

- Whether there are burrs on the edges of the bar. Remove these with a file if necessary.
- Whether the groove in the bar has become badly worn. Replace the bar if necessary.

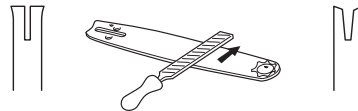

- Whether the tip of the bar is uneven or badly worn. If a hollow forms on the underside of the bar tip this is due to running with a slack chain.

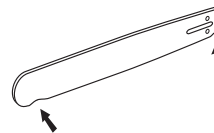

To prolong the life of the bar you should turn it over daily.

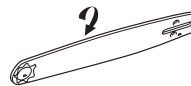

WARNING! A faulty cutting attachment may increase the risk of accidents.

Safety instructions for using a pruning saw



WARNING! The machine can cause serious personal injury. Read the safety instructions carefully. Learn how to use the machine.



WARNING! Cutting tool. Do not touch the tool without first switching off the engine.

CAUTION! Please read the operator's manual carefully and make sure you understand the instructions before using the machine.

SAFETY INSTRUCTIONS

Personal protection

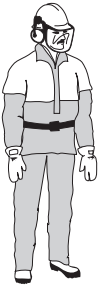

- Always wear boots and other equipment described under the heading Personal protective equipment in the machine's Operator's Manual.
- Always wear working clothes and heavy-duty long trousers.
- Never wear loose clothing or jewellery.
- Make sure your hair does not hang below shoulder level.

Safety instructions regarding the surroundings

- Never allow children to use the machine.
- Ensure that no-one comes closer than 15 m while you are working.
- Never allow anyone else to use the machine without first ensuring that they have understood the contents of the operator's manual.
- Never work from a ladder, stool or any other raised position that is not fully secured.



Safety instructions while working

- Always ensure you have a safe and stable working position.
- Always use both hands to hold the machine. Hold the machine at the side of your body.



- Use your right hand to control the throttle setting.
- Make sure that your hands and feet do not come near the cutting attachment when the engine is running.
- When the engine is switched off, keep your hands and feet away from the cutting attachment until it has stopped completely.

- Watch out for stumps of branches that can be thrown out during cutting.
- Always lay the machine on the ground when you are not using it.
- Check the working area for foreign objects such as electricity cables, insects and animals, etc, or other objects that could damage the cutting attachment, such as metal items.
- If any foreign object is hit or if vibrations occur stop the machine immediately. Disconnect the HT lead from the spark plug. Check that the machine is not damaged. Repair any damage.
- If anything gets caught up in the cutting attachment while you are working, switch off the engine and let it stop completely before cleaning the cutting attachment.

Safety instructions after completing work



- The transport guard should always be fitted to the cutting attachment when the machine is not in use.
- Make sure the cutting attachment has stopped before cleaning, carrying out repairs or an inspection. Disconnect the HT lead from the spark plug.
- Always wear heavy-duty gloves when repairing the cutting attachment. This is extremely sharp and can easily cause cuts.

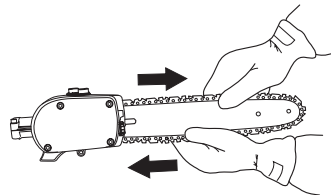

- Store the machine out of reach of children.
- Use only original spare parts for repairs.

Basic working techniques

- Hold the machine as close to your body as possible to get the best balance.



- Make sure that the tip does not touch the ground.
- Do not rush the work, but work steadily until all the branches have been cut back cleanly.
- Always slow the engine to idle speed after each working operation. Long periods at full throttle without any load on the engine can lead to serious engine damage.
- Always work at full throttle.

SAFETY INSTRUCTIONS

- Let the engine drop back to idle speed between each cut. Long periods at full throttle can cause serious damage to the centrifugal clutch.



WARNING! Never stand directly underneath a branch that is being cut. This could lead to serious or even fatal personal injury.

Observe great care when working close to overhead power lines. Falling branches can result in short-circuiting.



WARNING! Observe the applicable safety regulations for work in the vicinity of overhead power lines.



WARNING! This machine is not electrically insulated. If the machine touches or comes close to high-voltage power lines it could lead to death or serious bodily injury. Electricity can jump from one point to another by arcing. The higher the voltage, the greater the distance electricity can jump. Electricity can also travel through branches and other objects, especially if they are wet. Always keep a distance of at least 10 m between the machine and high-voltage power lines and/or any objects that are touching them. If have to work within this safe distance you should always contact the relevant power company to make sure the power is switched off before you start work.



WARNING! This machine has a long reach. Make sure that no people or animals come closer than 15 m when the machine is running.

- Whenever possible position yourself so that you can make the cut at right angles to the branch.

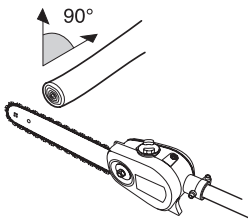

- Do not work with the shaft held straight out in front of you (like a fishing rod) as this increases the apparent weight of the cutting attachment.

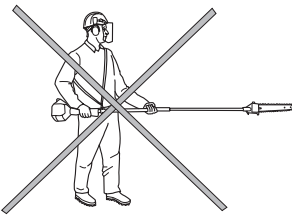

- Cut large branches in sections so that you have better control over where they fall.

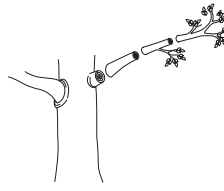

- Never cut through the swelling at the root of the branch as this will slow down healing and increase the risk of fungal attack!

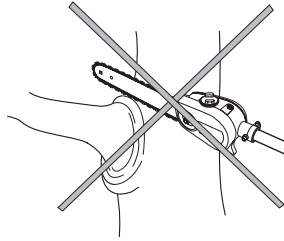

- Use the stop at the base of the cutting head to provide support during cutting. This will help prevent the cutting attachment from "jumping" on the branch.

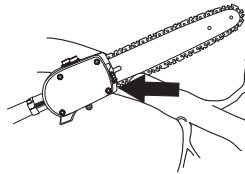

- Make an initial cut on the underside of the branch before cutting through the branch. This will prevent tearing of the bark, which could lead to slow healing and cause permanent damage to the tree. The cut should not be deeper than 1/3 of the branch thickness to prevent jamming. Keep the chain running while you withdraw the cutting attachment from the branch to prevent it jamming.

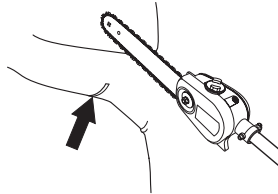

- Use the harness to support the weight of the machine and make it easier to handle.
- Make sure you have a firm footing and that you can work without being hampered by branches, stones and trees.



WARNING! Never activate the throttle without having the cutting attachment in full view.

WHAT IS WHAT?

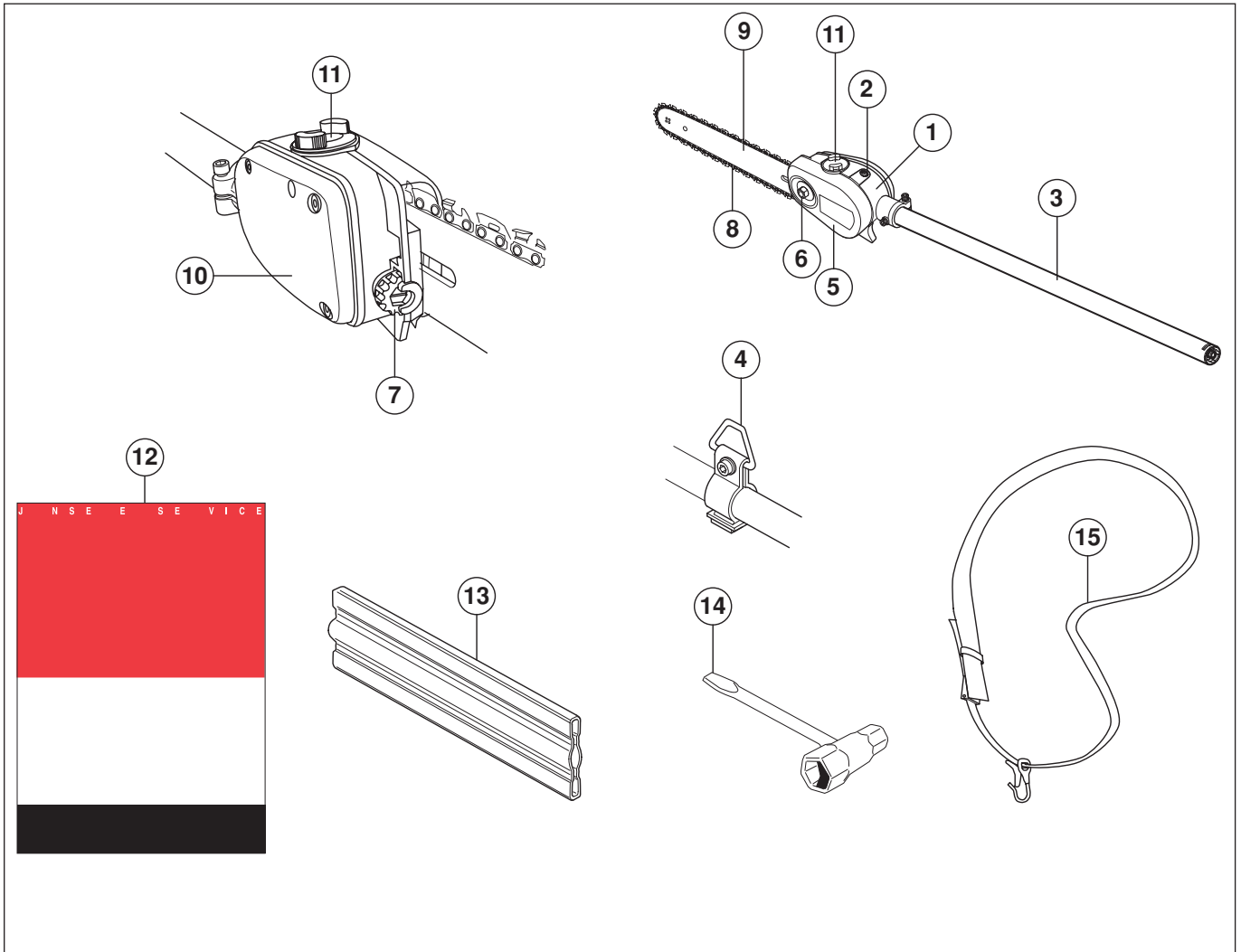

What is what on the saw attachment? (Saw attachment with shaft PA 1100)

- | | |
|--------------------------------------|---------------------------|
| 1 Bevel gear | 9 Bar |
| 2 Chain lubrication adjustment screw | 10 Chain oil tank |
| 3 Shaft (1100 mm) | 11 Filling with chain oil |
| 4 Harness support hook | 12 Operator's manual |
| 5 Protective guard for saw chain | 13 Transport guard |
| 6 Bar nut | 14 Combination spanner |
| 7 Chain tensioning screw | 15 Harness |
| 8 Chain | |

WHAT IS WHAT?

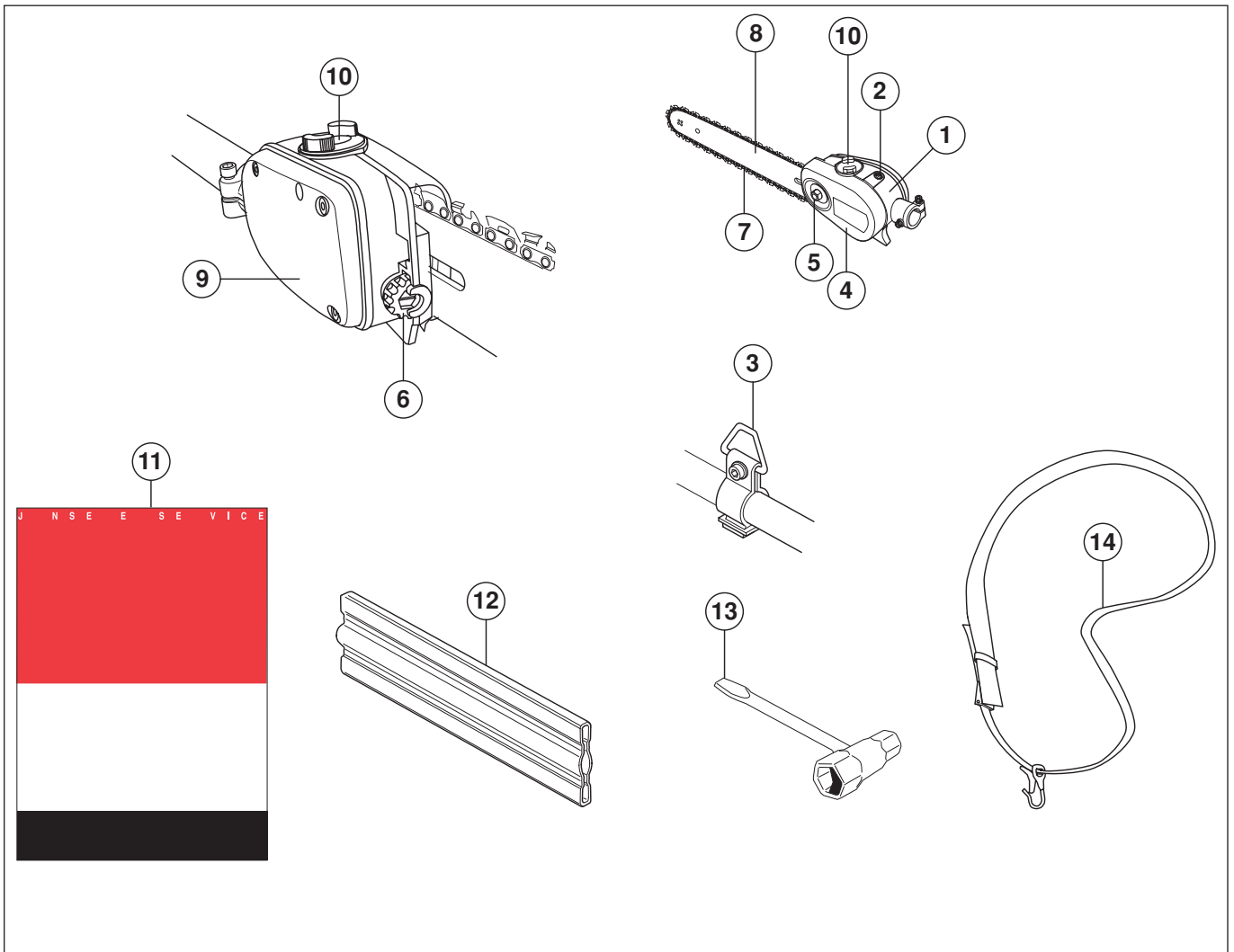

What is what on the saw attachment? (Saw attachment without shaft PA)

- | | |
|--------------------------------------|---------------------------|
| 1 Bevel gear | 8 Bar |
| 2 Chain lubrication adjustment screw | 9 Chain oil tank |
| 3 Harness support hook | 10 Filling with chain oil |
| 4 Protective guard for saw chain | 11 Operator's manual |
| 5 Bar nut | 12 Transport guard |
| 6 Chain tensioning screw | 13 Combination spanner |
| 7 Chain | 14 Harness |

ASSEMBLY

Fitting the cutting head

(Saw attachment with shaft PA 1100)



- Fit the cutting head on the shaft so that the screw (A) is aligned with the hole in the shaft as shown.

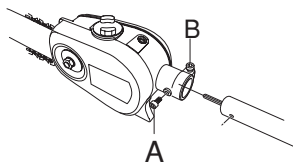

- Tighten screw A.
- Tighten screw B.

CAUTION! Make sure that the drive shaft inside the shaft engages with the cut-out in the cutting head.

Fitting the cutting head

(Saw attachment without shaft PA)



- Remove the mitre gear from the shaft.

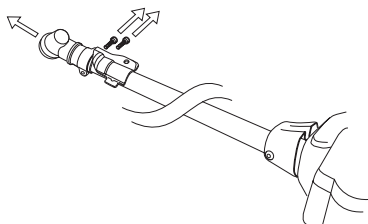

- Fit the cutting attachment to the shaft.

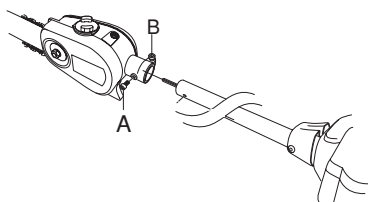

- Tighten screw A.
- Tighten screw B.

CAUTION! Make sure that the drive shaft inside the shaft engages with the cut-out in the cutting head.

Fitting the bar and chain

- Unscrew the bar nut and remove the protective cover.
- Fit the bar over the bar bolt. Place the bar in its rearmost position. Place the chain over the drive sprocket and in the groove on the bar. Begin on the top side of the bar.
- Make sure that the edges of the cutting links are facing forward on the top edge of the bar.
- Fit the cover and locate the chain adjuster pin (A) in the hole in the bar. Check that the drive links of the chain fit correctly on the drive sprocket (B) and that the chain is in the groove in the bar (C). Tighten the bar nut finger-tight.

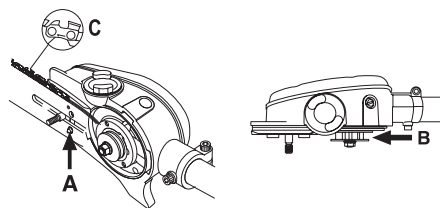

- Tension the chain by turning the chain tensioning screw clockwise using the combination spanner. The chain should be tensioned until it does not sag from the underside of the bar.

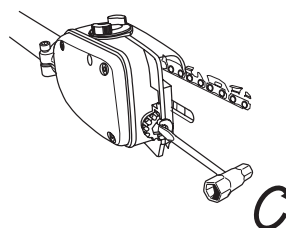

- The chain is correctly tensioned when it does not sag from the underside of the bar, but can still be turned easily by hand. Hold up the bar tip and tighten the bar nuts with the combination spanner.

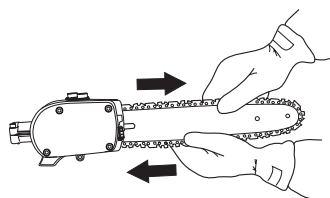

- When fitting a new chain, the chain tension has to be checked frequently until the chain is run-in. Check the chain tension regularly. A correctly tensioned chain ensures good cutting performance and long life.

Fitting the hanging ring



Fit the hanging ring between the rear handle and the loop handle. Position the hanging ring so that the machine is balanced and comfortable to work with.

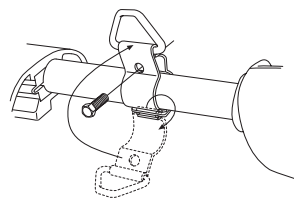

ASSEMBLY

Adjusting the harness



You should always use the harness with the machine to give maximum control over the machine and reduce the risk of fatigue in your arms and back.

- Put on the harness.
- Hook the machine onto the harness support hook.
- Adjust the length of the harness so that the support hook is roughly level with your right hip.



Filling with oil

- Open the cap on top of the bar head

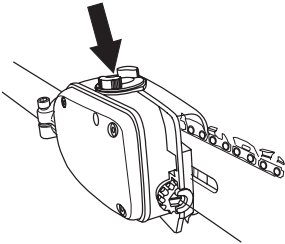

- Fill with Jonsered saw chain oil.
- Refit the cap.

Check before starting

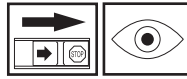

- Inspect the working area. Remove any objects that could be thrown out.
- Check the cutting attachment. Never use blunt, cracked or damaged equipment.
- Check that the machine is in perfect working order. Check that all nuts and screws are tight.
- Make sure the chain is adequately lubricated. See instructions under the heading Lubricating the cutting attachment.
- Check that the cutting attachment always stops when the engine is idling.
- Only use the machine for the purpose it was intended for.
- Make sure the handle and safety features are in order. Never use a machine that has any parts missing or has been modified in relation to the specification.



TECHNICAL DATA

Technical data



| Technical data | Saw attachment without shaft PA | Saw attachment with shaft PA 1100 |
|---|---------------------------------|-----------------------------------|
| Lubrication system | | |
| Oil tank capacity, litre | 0,22 | 0,22 |
| Weight | | |
| Weight without fuel, cutting attachment and guard, kg | 0,8 | 1,4 |
| Sound levels | | |
| (see note 1) | | |
| Equivalent noise pressure level at the user's ear, measured according to EN ISO 11680-1, dB(A) | 95 | 96 |
| Equivalent noise power level at the user's ear, measured according to EN/ISO 11680-1 and ISO 10884, dB(A) | 106 | 106 |
| Vibration levels | | |
| Vibration levels on the handles, measured according to EN/ISO 11680 m/s ² | | |
| When idling, rear/front handles: | 1,0/3,0 | 1,2/2,3 |
| At max. speed, rear/front handles: | 5,5/3,6 | 6,0/5,5 |

Note 1: Equivalent sound pressure level is calculated as the time-weighted energy total for sound pressure levels under various working conditions with the following time distribution: 1/2 idling and 1/2 max speed.

Bar and chain combinations

The following combinations are CE approved.

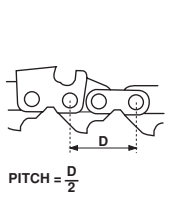
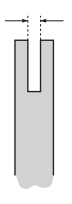
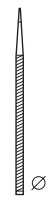
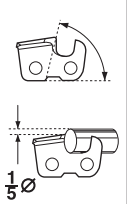
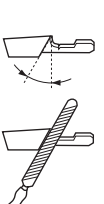
| Length, inches | Bar | | Chain | | | | | |
|----------------|-------------|----------------------------------|----------------------------|--|--|--|--|--|
| | Pitch, inch | Max. no of teeth on tip sprocket | | | | | | |
| 12 | 3/8 | 7 T | Jonsered S 36/Oregon 91 VG | | | | | |
| 12 | 3/8 | 7 T | Oregon 90SG | | | | | |

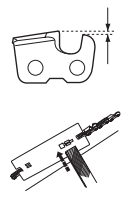
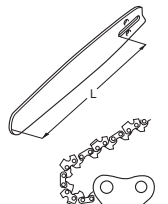
| |  |  |  |  |  |  |  |  |
|------|---|---|---|---|---|--|---|---|
| | inch | inch/mm | inch/mm | | | | inch/mm | inch/cm: dl |
| 91VG | 3/8" | 0,050"/1,3 | 5/32" /4,0 | 85° | 30° | 0° | 0,025"/0,65 | 10"/25:40 12"/30:45 |
| S36 | 3/8" | 0,050"/1,3 | 5/32" /4,0 | 85° | 30° | 0° | 0,025"/0,65 | 10"/25:40 12"/30:45 |
| 90SG | 3/8" | 0,028"/1,1 | 5/32" /4,0 | 85° | 30° | 0° | 0,025"/0,65 | 10"/25:40 12"/30:45 |

TECHNICAL DATA

EC-declaration of conformity

(Applies to Europe only)

We, Jonsered, SE-561 82 Huskvarna, Sweden, tel +46-36-146500, declare that this saw attachment from 2002's serial numbers and onwards (the year is clearly stated in plain text on the type plate, with subsequent serial number), complies with the requirements of the COUNCIL'S DIRECTIVE:

of June 22, 1998 "relating to machinery" **98/37/EC**, annex IIA.

The following standards have been applied: **EN 292-2, EN ISO 11680-1**

Notified body: **0404, SMP Svensk Maskinprovning AB**, Fyrisborgsgatan 3, SE-754 50 Uppsala, Sweden, has carried out EC type examination in accordance with the machinery directive's (98/37/EC) article 8, point 2c. The certificate for EC type examination in accordance with annex VI, has number: **404/02/858**

The supplied saw attachment conforms to the example that underwent EC type examination.

Huskvarna January 3, 2002



Bo Andréasson, Development manager

.Jonsered

1150077-20



2005-04-18